

Small Oil Expeller for Rural Areas of Bangladesh

M. D. Hussain¹, M. R. Ali^{2*} and H. Habib³

Abstract

Electric powered small oil expeller was constructed and installed at Bangladesh Agricultural University campus and in Modhupur forest area using the available information of big expellers imported from Japan. The capacity of the expeller was 40 kg/hr which with big expeller was 100 kg/hr. The oil extraction efficiency was 75.44 percent while the machine was running at 36 rpm. The factors which affect oil extraction from this expeller were determined. Moisture content of seeds should be 10-12 percent and 1-2 percent moisture addition is essential before expelling. Considering time and oil recovery, 36 rpm was referred for this expeller. The inside temperature of the expeller gradually increases from 30 to 65°C for one batch and it took about 30 min. Materials required for the construction of the small expeller are described in the article. All materials are available in the local market. Local artisans with little training will be able to fabricate the small expellers. About 30 man days are required to fabricate the whole expeller system. The machine frequently needs repairing of its worm screws at an interval of 60 to 40 working days or crushing of 16,000 kg seeds.

Key words: Oil seeds, Oil expeller, Screw press, Oil recovery

1. Introduction

Edible oils are derived from animals and plants (Sangha *et al.*, 2004). Oils from plants are classified as vegetable oil. The largest sources of vegetable oils are annual plants, which include soybeans, corn, cottonseed, groundnut, sunflower, rapeseed, melon and sesame seed (Frank, 1998 and O'Brien, 1998). Other sources are oil bearing perennial plants such as olive, coconut, shear, cashew and palm.

Most of the developing countries have large-scale oilseed processing facilities which are generally located in urban areas. Oilseeds grown in rural areas are normally transported to the urban oil mills for processing, but poorly maintained roads and vehicles make the transporting of oilseeds from rural areas to urban oil mills both difficult and costly. The high urban demand for vegetable oil leads to shortages in rural areas. Oil that does reach the rural areas is sold at a much higher price than in the city.

Separation of oil from oilseeds is an important operation for processing. The process employed has a direct effect on quality and quantity of protein and oil obtained from the oilseeds. Basically two methods are used for this purpose. One is the solvent extraction method which is most popular in United State, is highly efficient (over 98% oil recovery) and a single extractor can handle very large capacities (up to 4000 ton/day). The method, however, requires a large infrastructure with high initial cost and there are fire and pollution hazards as it requires large quantities of highly flammable solvents.

The other method used involves mechanical expeller. In this process, the pre conditioned oil is pressed through a screw press where a combination of high temperature and shear is used to crush the oilseed to release the oil. The method is relatively less efficient as it recovers only 70-80% of the available oil, depending on the oilseed and pressure applied. Pretreatment and operating conditions determine the efficiency of the screw press but each press can handle much smaller quantity of oilseeds (up to 1000 ton/day). The method is low initial and operating costs compared to the solvent method and is relatively free of any polluting or fire hazardous substances.

Ghani was only traditional device in Bangladesh to extract oil from mustard, sesame, ricinus (*redii*) and meat of ripe coconut, etc. This is purposely done to keep the animal moving only in the frontal circular direction. As the population of draught animal is decreasing very rapidly, animal driven rural oil expellers are becoming

¹Professor, ²Associate Professor, ³Research Associate, Department of Farm Power and Machinery, Bangladesh Agricultural University, Mymensingh-2202, Bangladesh

*Corresponding address: E-mail: engr_rustomfpm@yahoo.com

scarce in use in the rural areas of Bangladesh. Presently rural electrification board is giving electric connection to rural areas and electric driven machines are also increasing day by day. Now time has come to design and fabricate electric powered oil extracting machines for farmers use. Considering the above facts, electric powered oil expeller could be designed and installed in the rural areas and performance studies of its operation could be undertaken. Based on the above discussion the main objective of the study is to design the oil expeller and its fabrication to use with the rural farmers and to compare the performance with existing oil expellers in use.

2. Materials and Methods

An expeller press is a screw-type machine that presses oil seeds through a caged barrel-like cavity. Raw materials enter one side of the press and waste products exit the other side. The machine uses friction and continuous pressure from the screw drives to move and compress the seed material. The oil seeps through small openings that do not allow solids of seed fiber to pass through. Afterward, the pressed seeds are formed into a hardened cake, which is removed from the machine. Pressure involved in expeller pressing creates heat in the range of 140-210°F (60-99°C) (Adeeko *et al.*, 1990).

Screw oil press is mainly composed of shift gears, press cage, feeder, press screw, and machine frame. These five parts constitute the structure of screw oil press. The screw type seed oil expeller is a crude oil processing equipment. The different views of the oil expeller are shown in Fig.1. For efficient collection of the extracted oil, individual dishes were used for each sample at the base of the expeller. A digital balance was used to weigh the dish with extracted oil. The oil recovery was calculated using the following formula:

$$\text{Oil recovery (\%)} = (\text{weight of oil extracted, g} / \text{Initial weight of oil present in sample, g}) \times 100$$

Each sample needed 6 to 7 times re-crushing and the yield of recovered oil in each time was also calculated.

The effect of worm speed on the expeller, oil recovery, oil in press cake, temperature in the crushing chamber and pressing rate were observed during experiment. The worm speed varies changing pulley diameter of the motor.

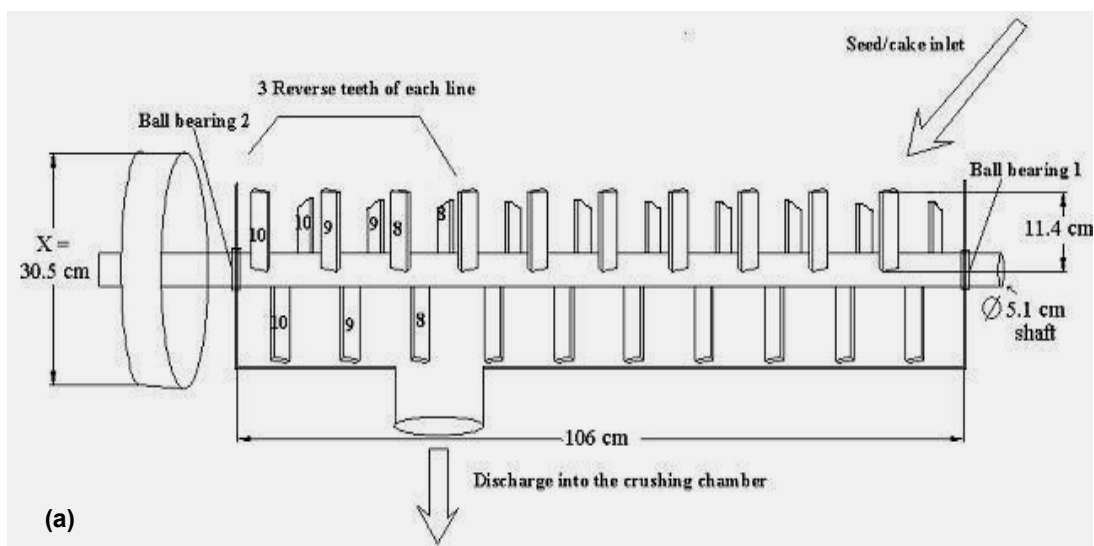

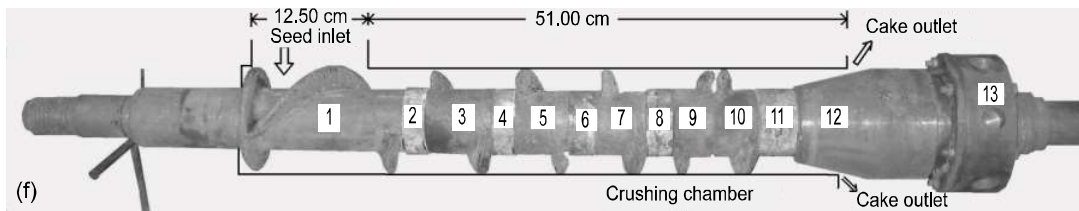
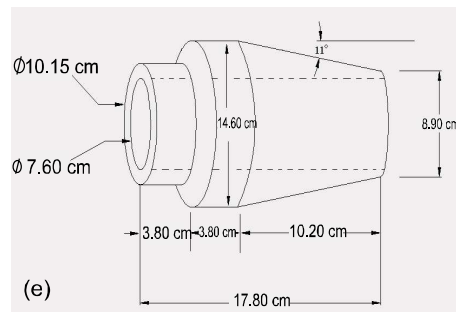
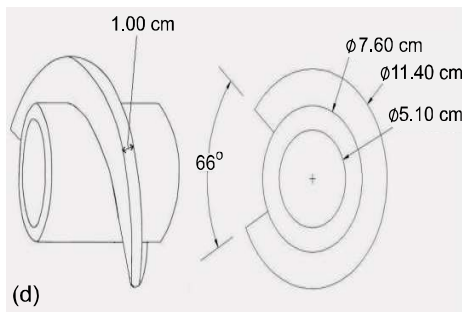
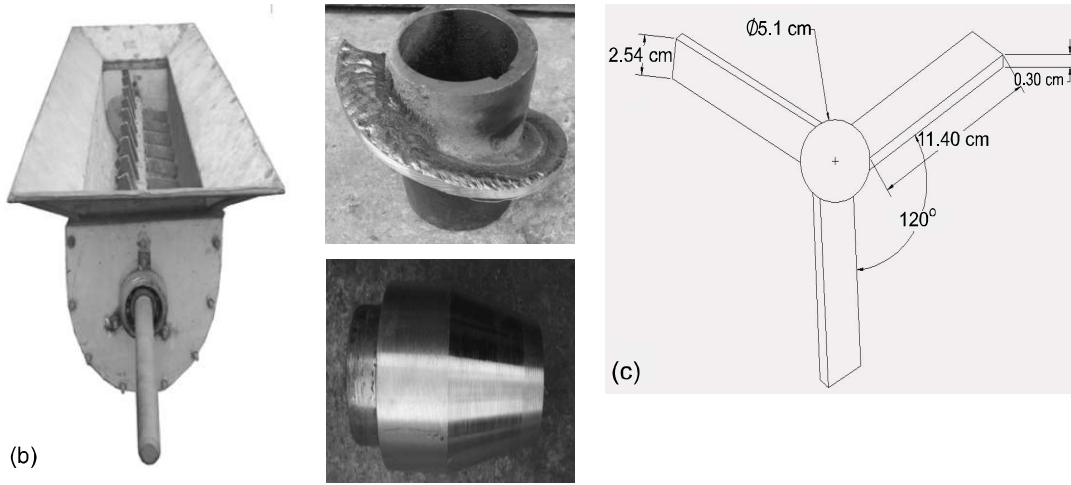



Fig. 1. Different views of the oil expeller: (a) arrangement of agitator in the shaft of the hopper, (b) photographic view of the hopper (c) side view of the shaft of the hopper (d) an worm screw (e) cone of the expeller (f) main shaft of the expeller (g) assembly of the screws in the crushing chamber and (h) assembly of the whole expeller and frame for setup.

3. Results and Discussions

A small oil expeller for mustard and other mustard like seeds was developed. The small expeller was constructed from a large expeller imported from Japan by following the Reverse Engineering Principle. The length was reduced from 259 cm to 137 cm, diameter of the crushing chamber was reduced from 16.5 cm to 11.5 cm and other parts were reduced in the same way. Reduction in size decreased production capacity and the construction price, as a result small entrepreneur can easily adapt this technology.

3.1 Moisture content

Sand and dirt were removed from the collected seeds. After cleaning, moisture content of three samples was calculated as shown in Table 1.

Table 1. Initial moisture content of samples M_1 , M_2 and M_3

Sample No.	Initial wt. (gm)	Final wt. (gm)	MC (%)	Average MC (%)
M_1	10.0	9.14	9.41	9.34
	10.5	9.61	9.26	
	10.3	9.42	9.34	
M_2	8.6	7.86	9.41	9.30
	10.7	9.79	9.30	
	10.1	9.25	9.19	
M_3	12.5	11.42	9.46	9.35
	11.2	10.25	9.27	
	11.6	10.61	9.33	

Table 1 shows that the average moisture content was in the range of 9.30 to 9.35% which is appropriate for safe storage condition. Addition of moisture improves oil recovery (Sivala *et al.*, 1991), so about 2.0% moisture was added to improve oil recovery. Therefore, before crushing moisture content was 11.5 to 12%.

3.2 Performance test of the expeller

Performance test of the expeller was conducted with mustard seeds and the experimental data is shown in Table 2.

The testing results suggests that the performance of the machine is highly dependent on the speed of the worm screw, time required to press the seeds and the quantity of the material passing through the machine with expelling operation. The machine showed its best performance at around 30 rpm, but it took too much time. Comparing oil recovery and power consumed by electric motor (10 kW 3 phase 440 volts), 36 rpm was effective for this expeller.

Table 2. Mean performance study of the expeller for mustard seeds

Worm speed (rpm)	Initial weight (kg)	Oil content (%)	Recoverable oil (kg)	Oil recovered (kg)	Time required (min)	Cake output rate (kg/hr)	Oil in pressed cake, %	Efficiency, %
30	15	38	5.7	4.51	42	0.035	9.1	79.12
36	15	38	5.7	4.3	31	0.044	9.75	75.44
42	15	38	5.7	4.0	26	0.053	10.6	70.18

3.3 Oil recovery

For a sample it needs to repress the cakes for maximum oil recovery. The repressing number can be defined as stroke and for mustard seeds it is nearly 7 strokes. Oil recovered for every stroke is shown in Fig. 2.

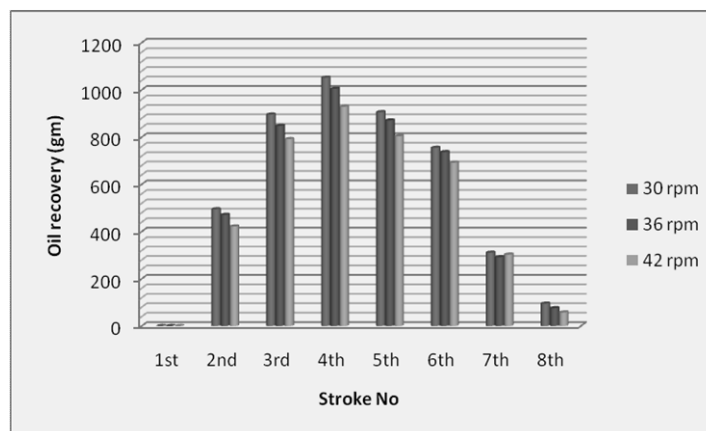

Fig. 2. Oil recovery for every stroke for 15-kg sample

The graph shows that the first stroke only grinds the seeds. Oil recovery starts from second stroke and it gradually increases till fourth stroke where it reached at maximum value. From fifth stroke the amount of oil recovery reduces gradually. After seventh stroke there is a little amount of oil remained in cake which cannot be extracted by mechanical extraction.

3.4 Effect of worm screw speed on oil recovery

Oil recovery has a negative effect on the speed of the screw. The result of increasing worm screw speed is shown in Fig. 3.

Figure 3 shows that the oil recovery from this expeller decreased with increase wormshaft speed from 30 to 42 rpm when moisture content of seed and other factors were kept constant. The result shows that lower

speed of the wormshaft increase oil recovery but considering other factors such as time required, labour cost and financial analysis mentioned in Table 3, 36 rpm was economic.

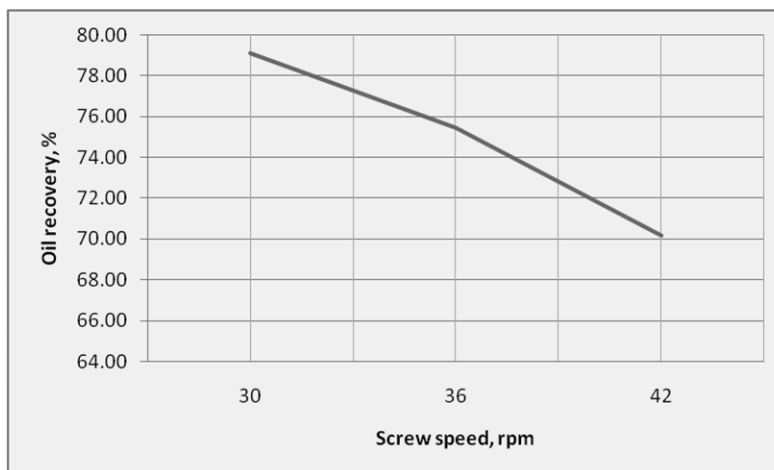

Fig. 3. Effect of screw speed on oil recovery

Table 3. Financial Analysis

a. Cost of production (per annum)

Description	Amount (Tk. lac)
Recurring expenses	29.83
Depreciation on building @5%	0.07
Depreciation on machinery @10%	0.30
Depreciation on furniture @20%	0.02
Interest on Capital Investment @12%	1.51
Total	31.73

b. Sales/yr

Item	Quantity	Rate (Tk.)	Amount (Tk. lac)
Mustard oil	23400 kg	120/kg	28.08
Mustard cake	42.50 MT	25000/MT	10.63
Total			38.71

c. Total capital investment

Description	Amount (Tk. lac)
Fixed capital	5.10
Working capital	7.46
Total	12.56

d. Annual fixed cost

Annual Fixed Cost	Amount (Tk. lac)
All depreciation	0.39
Interest	1.51
40% of salary, wages, utility, contingency	1.15
Insurance	0.05
Total	3.10

e. Financial parameters

Items	Amount (Tk. lac)
Net profit/yr (38.71 – 31.73)	6.98
Net profit ratio (6.98/38.71)*100	18.03%
Rate of return on investment (6.98/12.56)*100	55.57%
Break Even Point (3.10*100/3.10+6.98)	30.75%

3.5 Effect of screw speed on oil remained in press cake

A significant amount of oil remained in pressed cake in mechanical extraction. The amount of oil in pressed cake depends on wormshaft speed. The effect of wormshaft speed on oil remained in pressed cake is shown in Fig. 4.

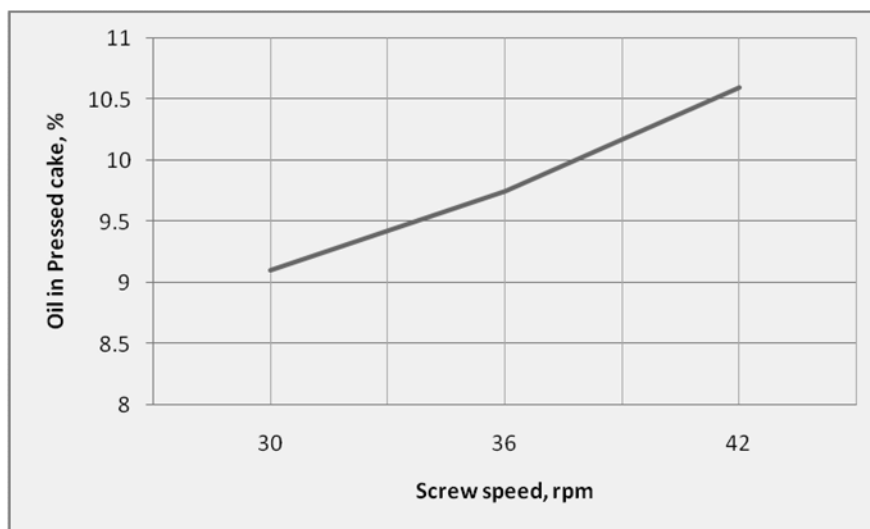

Fig. 4. Effect of screw speed on oil remained in pressed cake

From Fig. 4 it can be shown that the oil remained in pressed cake increased with increase screw speed. That means for higher speed the screw got less time to press the seeds and passed them rapidly, as a result the amount of oil in pressed cake was higher.

3.6 Effect of screw speed on press rate

The press rate that means cake output rate (kg/hr) is directly proportional with screw speed for screw type expeller. The result obtained for this expeller is shown in Fig. 5.

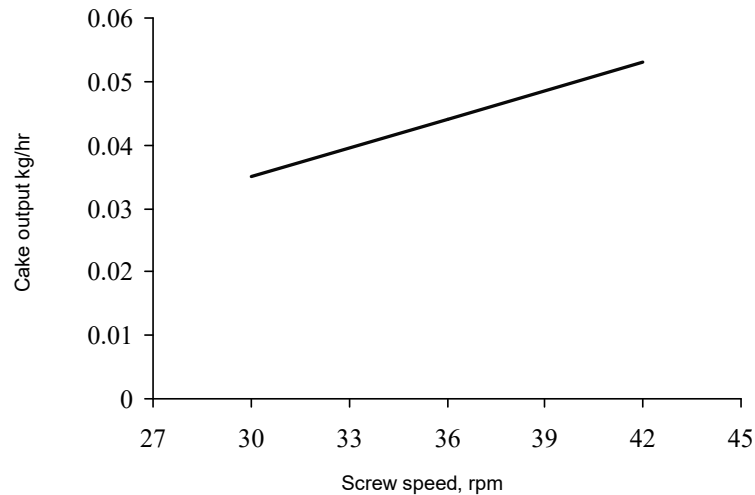

Fig. 5. Effect of screw speed on cake output rate

Figure 5 shows that the press rate increased with increase screw speed from 30 to 42 rpm. When screw speed was higher, it passed the seeds rapidly through the screw as a result it took less time to press the seeds and oil recovery was reduced. On the other hand, when screw speed was less, it got much time to press the seeds leading to higher recovery of oil.

3.7 Effect of screw speed on temperature

Temperature is one of the key factor for extracting oil from oilseeds by mechanical method of oil extraction. The temperature rise throughout the process is shown in Fig. 6.

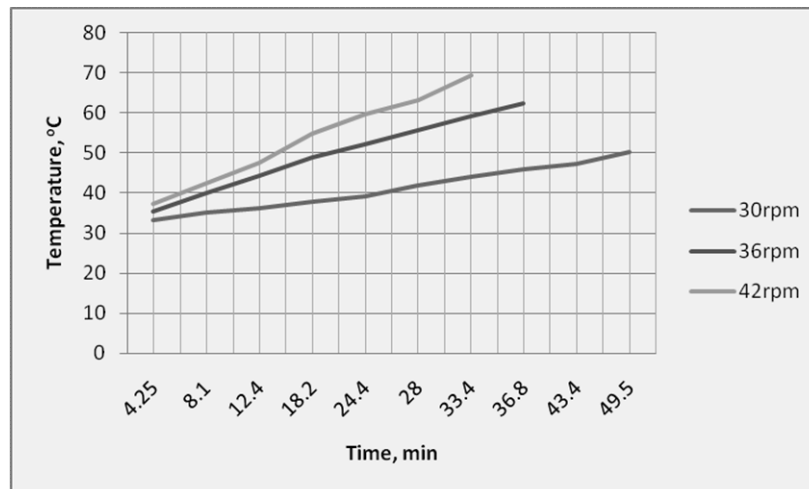

Fig. 6. Effect of screw speed on temperature inside crushing chamber

Figure 6 shows that temperature inside the crushing chamber was increased simultaneously with time. Rate of temperature increase was much higher for screw speed 42 rpm and the rate of temperature increase was lower for lower screw speed. The temperature was increased from 28°C (ambient temperature) to 51°C for

30 rpm, 64°C for 36 rpm and 70°C for 42 rpm of the shaft for a batch of sample. At temperature higher than 65°C the oil became dark and burnt meal was produced.

3.8 Comparison of different sizes of expeller

The length, diameter of the crushing chamber, capacity and wear rate etc. of available expellers in Bangladesh is given in Table 4.

Table 4. Dimension, capacity and wear rate of available expellers in Bangladesh.

Size of the machine (length, cm)	Dia. of the crushing chamber (cm)	Height of worm screw (cm)	Capacity (kg/hr)	Total wear rate of the worm screw (cm/1000 kg)	Maximum seed crushed (kg)
168	14.0	3.2	50	0.029	24000
198	14.0	3.2	60	0.023	30000
259	16.5	3.5	100	0.016	36000
137 (developed)	11.5	1.9	40	0.025	16000

Table 4 shows that, the developed expeller is smaller than the existing expellers and expelling capacity is 40 kg/hr. The wear rate was estimated 0.025 cm/1000 kg that means after crushing 16000 kg seeds, the worm needs to repair.

4. Conclusions

A small oil expeller with a capacity of 40 kg/hr was developed. Evaluation of the machine on mustard seed gave an expelling efficiency of 75.44% at the speed of 36 rpm, and the expeller was operated with the electric motor (10 kW 3 phase 440 volts). Design and drawings presented in the article will help for manufacturing and marketing the standard oil expelling units for the benefit of the processors and the manufacturers. The processing capacity of this small expeller is estimated to be 40 kg/hr for mustard. Seed variety, seed size, moisture content of seed, addition of water before crushing, temperature, pressure, pressing time and worm screw speed have a great influence on oil yield from the expeller. The oil recovery from mustard seeds for this machine was 70-79% depending on the variable factors. This simple but standard and efficient technology can be installed at a relatively small investment.

References

- Adeeko K A and Ajibola O O 1990. Factors affecting the expression of oil from groundnut. *Journal of Agricultural Engineering Research*, 45(2): 45-53.
- Frank T O 1998. Vegetable oils. *Bailey's Industrial Oil and Fat Product*. 1: 19-44.
- O' Brien R D 1998. Fats and oils, formulating and processing for applications. Technical Publishing, Company Inc. Lancaster USA.
- Sangha M, Gupta P, Thapar V and Verma S 2004. Storage studies on plant oils and their methyl esters. *Agricultural Engineering International: the CIGR Journal of Scientific Research and Development*. VI.
- Sivala K, Bhole N G and Mukherjee R K 1991. Effect of moisture on mustard oil expression. *Journal of Agricultural Engineering Research*, 50: 81-91.