

ON FARM PERFORMANCE OF MANUAL PUMPS

M. A. Haque¹ M. D. Hussain² M. A. Zaman²

[Date Received : 05.11.1996]

Keywords : Manual pumps, Treadle pump, Rower pump, Hand pump, Performance

ABSTRACT

This paper describes the on farm performances of three manually operated pumps widely used in Bangladesh namely, twin treadle pump, rower pump and No. 6 hand pump. Discharges from the treadle pump, rower pump and No. 6 hand pump at a head of 2.5 m were 0.66, 0.50 and 0.41 l/s respectively. Power input to the Rower pump and No. 6 Hand pump were 10% and 40% higher, respectively than that of the treadle pump at a head of 3.5 m. Treadle pump had the highest efficiency of 45% while the rower pump and the No. 6 hand pump had 38% and 25% efficiency, respectively. BCR values were 2.69, 1.83 and 1.17 respectively for the treadle pump, rower pump and No. 6 hand pump. The costs of lifting per m³ water were Tk. 6.46, Tk. 8.55 and Tk. 9.85 for the treadle, rower and No. 6 hand pump respectively. The overall performance of the twin treadle pump was better than rower and No. 6 hand pump up to a suction lift of 6 m. The No. 6 hand pump is not suitable for irrigation purpose because of its very low discharge and high power requirement.

INTRODUCTION

To supplement the huge and rapidly growing population of the country, more intensive cultivation of high yielding variety crops is essential for increased food production as the cultivable land is limited. Application of adequate irrigation at the right time is the main characteristic of HYV crops for better yield. Manually operated water lifting devices and pumps are widely used by the marginal farmers for irrigation as well as domestic use. The Fourth Five Year Plan (Planning Commission, 1990) of Bangladesh estimated that 4.242 million hectares of land are irrigated by different methods and 0.054 million hectares are irrigated by hand tube wells.

Due to high initial investment and increasing operating cost, it is far beyond the capacity of the marginal farmer to buy expensive and high capacity irrigation equipment. In addition there are other problems like fragmented land holdings scattered at different locations, irregular power supply, scarcity

and high price of fuel and spare parts, lack of repair and maintenance facilities and socio-economic constraints. Since the land holdings are small and fragmented, mechanical method of irrigation therefore requires a high level of cooperation for optimum utilization which is difficult to achieve (Abdullah, 1986). In this situation manually operated pumps play a vital role. Manual irrigation complements rather than substitutes for motorized pumps. At present 70% of farm households cultivate less than 1 ha. Small farmers like these, farming under 1 ha of land and with large reserves of family labour, form the obvious target group for manual pumps (Orr *et al.*, 1991).

Orr *et al.* (1991) revealed that the output of a treadle pump was higher than any other manual pump up to lifts of 3.5 m. They also found that the pump could irrigate comfortably about 0.41 ha of wheat or vegetables and one-third of this in case of rice.

¹ Assistant Professor, ² Professor

Department of Farm Power and Machinery, BAU, Mymensingh-2202, Bangladesh.

In determining the comparative performance of some manual pumps (other than treadle pump), Islam *et al.* (1981) found rower pump to be the best for the farmers requiring small scale irrigation.

Abdullah, M. (1986) tested the performances of manually operated pumps namely, tara, twin treadle and rower pump. He reported that with respect to head, discharge and efficiency, rower pump was better in comparison to the other two and that it could be successfully utilized for irrigation in areas where water table is within 6 m.

Most of the studies found in literature were laboratory based. The present study was, therefore, undertaken to evaluate the performance of twin treadle pump, rower pump and No. 6 hand pump at the farmers field level. The specific objectives of the study were :

- (a) To find power requirement of the pumps,
- (b) To find the head-discharge relationship, power input-discharge and power-head relationship, efficiency-discharge relationship and cumulative discharge of the pumps.

MATERIALS AND METHODS

Performances of three manually operated pumps namely, treadle pump (twin), rower pump and hand pump were studied at farm level in three different villages of Mymensingh Sadar Thana. Three types of pumps (Fig. 1) with the following specifications were studied.

- i) Treadle Pump : twin cylinder, 8.9 cm in diameter and 30 cm in length; 3.81 cm diameter suction pipe. Length of the left, middle and right space of the treadle were 55 cm, 30 cm and 88 cm, respectively.
- ii) Rower Pump : 5.1 cm diameter and 45.72 cm long PVC cylinder inclined at 30° to the horizontal; diameter of suction pipe was 3.81 cm.
- iii) No. 6 Hand Pump : 10.20 cm diameter cylinder and 12.70 cm diameter water chamber; diameter of suction pipe was 3.81 cm.

Each pump was tested at different heads. Pumping was done under normal field conditions by hired labourer. In each test the time of operation, number of strokes or cycle per minute, discharge per stroke, discharge per second, force required per stroke and efficiency were measured. Each test was replicated five times. The average of the five readings was taken as test data.

Measurements

Discharge : Water discharged from the pumps was collected in a container of 26 litre capacity which was graduated to litre marks. Thus Discharge/second was obtained by dividing the volume of water pumped by the pumping time. Operators operated the pumps for 20-25 minutes continuously and then made a break of 5-6 minutes. Average stroke lengths for the treadle, rower and No. 6 hand pump were 13, 38 and 40 cm, respectively.

Head : To obtain variable heads in the tube wells, the experiment was conducted at different times. Normally the ground water table comes up after monsoon and goes further down before monsoon. So, this fluctuation of ground water table with time permits to get variable heads to conduct the experiment on field conditions. Head was measured with the help of an avometer. In all the cases, head loss due to friction in the suction line was neglected.

Force : Due to lack of precision force measuring instruments, such as, load cell strain gauge, forces required to pull or push the pumps were measured approximately by a pull type spring balance. Abdullah (1986) reported that pulling force for treadle pump was zero and that on the lever of hand pump was negligible as compared to the pushing force. Force measuring techniques for all the pumps are shown in Fig. 2. For the treadle and No. 6 hand pump (Fig. 2a & 2c), taking moment at point A,

$$F = \frac{F_2 l_2}{l_1}$$

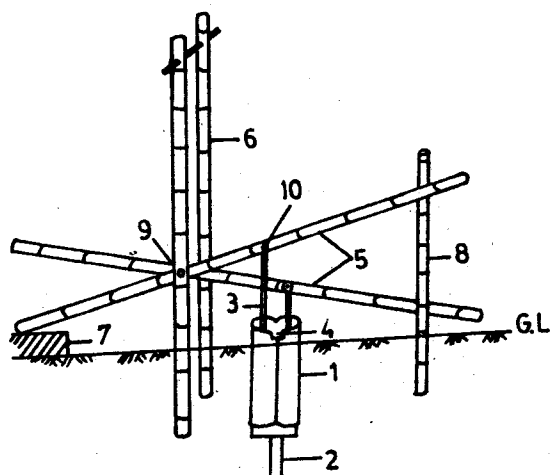

(a)

1. Pump cylinder
2. Suction pipe
3. Plunger rod
4. Spout
5. Treadles
6. Post
7. Stop bar
8. Guide post
9. Axis or Fulcrum
10. Plunger pin

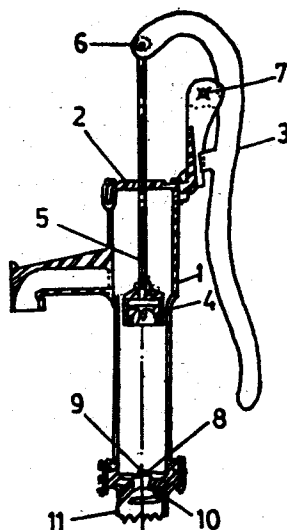

(c)

1. Pump body
2. Head cover
3. Handle
4. Plunger
5. Piston rod
6. Rod pin
7. Fulcrum pin
8. Flapper valve
9. Valve weight screw
10. Base plate
11. Inlet pipe

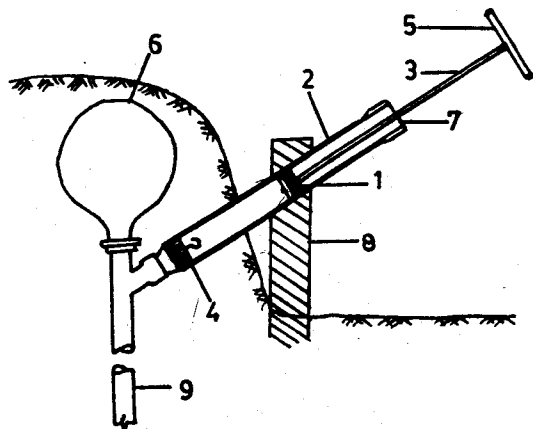

(b)

1. Piston
2. Suction cylinder
3. Piston rod
4. Foot valve
5. Handle
6. Surge chamber
7. Discharge end
8. Cylinder rest
9. Suction pipe

Fig. 1 Schematic diagram of the manual pumps under study
 (a) Twin treadle pump, (b) Rower pump, (c) No. 6 hand pump

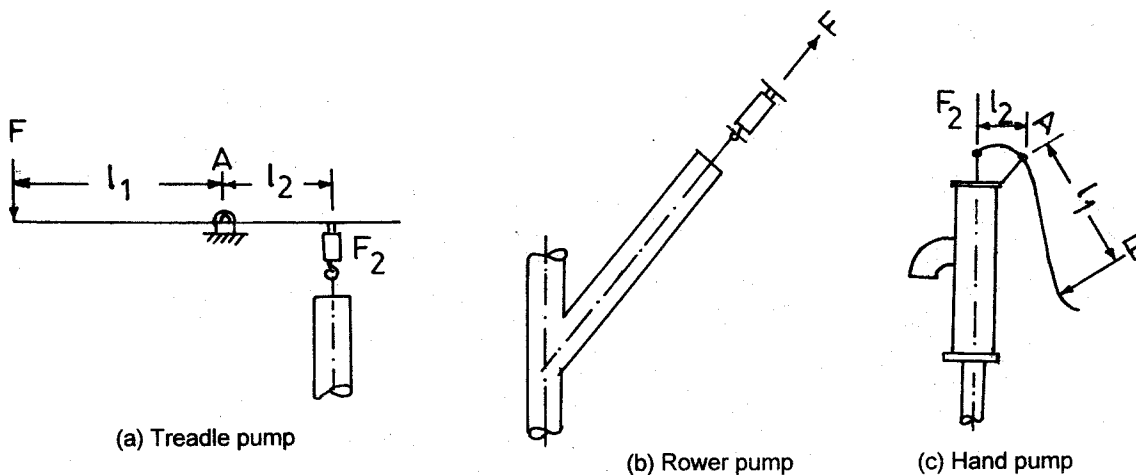

Fig. 2 Method of force measurement

where, F = force exerted by the operator, kg
 F_2 = force acting on the spring balance, kg
 l_1, l_2 = length of the force arms, m

Time and Linear Measurements

Time was recorded with a HEUER stop watch which can record up to 0.2 second. All the linear measurements were done by a steel tape or measuring tape.

Work, Power and Efficiency

The methods adopted by Abdullah (1986) were used to calculate work, power and efficiency. Work input to the pump per cycle is defined as the force applied to the pump handle multiplied by the stroke length or distance through which the handle moved in the direction of the force applied;

$$\text{i.e. } W_i = F \times S$$

where, W_i = work input per cycle or stroke, J
 F = average force, N
 S = stroke length, m

Work output by the pump per cycle is defined as the pressure provided to the water multiplied by the volume of water delivered per cycle or stroke.

$$\text{i.e. } W_o = P \times V = \rho g h V$$

where, $P = \rho g h$
 W_o = work output per cycle, J
 P = pressure, N/m^2
 v = volume of flow, m^3
 ρ = density of water, kg/m^3
 h = head, m
 g = gravitational acceleration, m/s^2

Power input to the pump per cycle is the total work done per cycle or stroke during continuous pumping divided by the time taken to complete the cycle.

$$\text{i.e. } P_i = \frac{F \times S}{t}$$

where, P_i = power input, W
 F = average force per cycle or stroke, N
 S = stroke length, m
 t = time taken to complete the stroke, sec

Water power output for pumping is defined as the useful work delivered by the pump per second.

$$P_o = wQH$$

where, P_o = water power output, W
 w = specific weight of water, N/m^3
 Q = discharge rate, m^3/sec
 H = head, m

Pump Efficiency is defined as the ratio of useful work output by the pump to the total work input to the pump.

$$\mu_p = \frac{\rho ghV}{F \times S} \times 100$$

where, μ_p = pump efficiency, percent

Cost of Lifting Water and Benefit-Cost Ratio

Benefit-cost ratio (BCR) and cost of lifting water were calculated on static method on the basis of present market value. BCR was calculated following the method adopted by Islam *et al.* (1992). For simplicity and uniformity, benefit (gross return) from each type of pump was calculated from the yields of boro paddy within the command area of 50, 40 and 30 decimal for treadle, rower and No. 6 hand pump, respectively. Cost of lifting water per m^3 was calculated following the procedure suggested by Molenaar (1956).

RESULTS AND DISCUSSIONS

Head-Discharge Relationship

An inverse relation was observed between head and discharge of all the pumps under study (Fig. 3), i.e. discharge decreases as the suction head increases. Discharge drops of 46%, 51% and 46% were found for the treadle, rower and hand pump, respectively at the lowest (2.24 – 2.32 m) and the highest (6.10 – 6.40 m) range of heads at which they were tested. At a normal operating head of 6 m the discharge of the rower pump was observed 14% higher than that of

the hand pump and the discharge of the treadle pump was 27% higher than the discharge of the rower pump. This trend of discharge were also found at a head of 2.5 m.

Power-Discharge and Power-Head Relationship

Fig. 4 shows that power input decreases with the increase in discharge. Apparently this may seem unusual which is clarified in Fig. 5 by plotting power against head. In this Figure it is evident that power increases with the increase in head. The antithesis in the relationship between the power-discharge and power-head is due to the fact that power is directly related to the force required to operate the pump and the force is proportional to head. As the head increases force required also increases but discharge decreases. So an inverse relation exists in Fig. 4.

Fig. 5 shows that as the head increases power input also increases but with the diminishing rate. Among the three pumps the No. 6 hand pump showed the highest power requirement as compared to the treadle and rower pumps in lifting ground water and the treadle pump required the lowest power. Fig. 5 also shows the average increase of power (within the lowest and the highest heads used in the test) as 12%, 14% and 10% for the treadle, rower and the No. 6 hand pump, respectively. Considering an operating head of 3.5 m the power requirement was observed to be about 28%, 10% and 40% higher comparing the Rower and the No. 6 hand pump, the treadle and the rower, the treadle and the hand pump respectively.

Efficiency-Discharge Relationship

Fig. 6 shows the relationship between efficiency and discharge of all the pumps under study. It was observed that the efficiency increased with the increase in discharge up to a certain limit and then began to fall with further increase in discharge. Efficiency was highest at a certain discharge corresponding to a particular head for all the pumps. Efficiency was observed to be less at low head

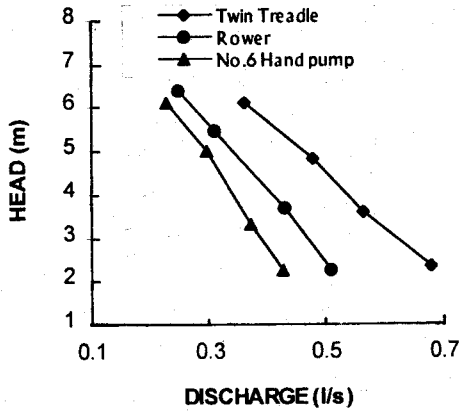

Fig. 3 Head-discharge relationship of treadle, rower and No. 6 hand pump

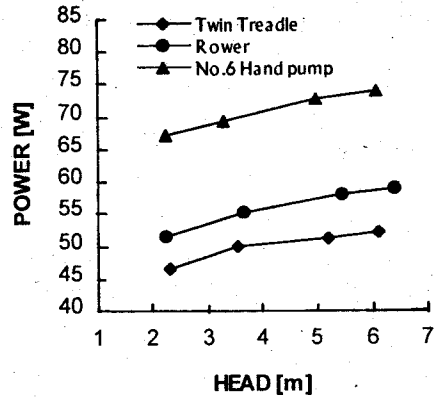

Fig. 5 Power-head relationship of treadle, rower and No. 6 hand pump

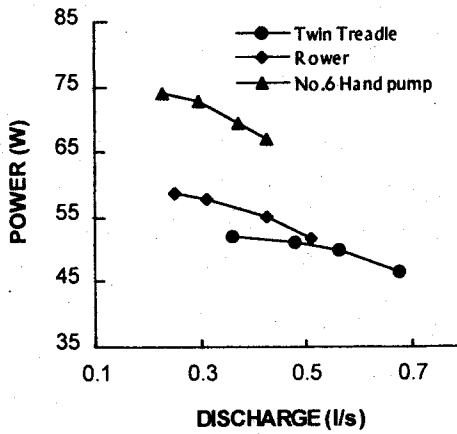

Fig. 4 Power-discharge relationship of treadle, rower and No. 6 hand pump

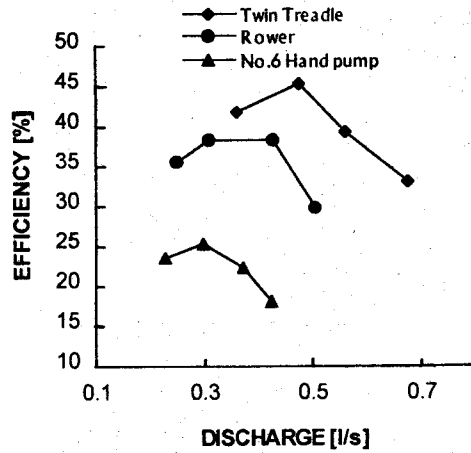

Fig. 6 Efficiency-discharge relationship of treadle, rower and No. 6 hand pump

Table 1. Benefit-cost ratio and cost of lifting water per m³ by three types of manual pumps.

| | Treadle pump | Rower pump | No. 6 hand pump | Source of water |
|------------------------------------------------------|--------------|------------|-----------------|-----------------|
| BCR (Full cost basis) | 2.69 | 1.83 | 1.17 | Ground water |
| Average water lifting cost (Tk./ m ³) | 6.46 | 8.55 | 9.85 | Ground water |

although the discharge was high. Also at high head the efficiency was found to be less due to high power requirement. Fig. 6 shows that the optimum heads at which the efficiency was found to be highest are 5.20 m, 3.68 m and 5.00 m for the treadle, rower and No. 6 hand pump respectively. The highest efficiency was recorded to be 45%, 38% and 25% for the treadle, rower and No. 6 hand pump respectively.

Cumulative Discharge

Fig. 7 shows cumulative discharge of all the pumps. These curves are plotted to show the cumulative volume of water lifted by the pumps at a certain head up to a working period of two hours. It was observed that after two hours of working period the volume of water lifted by the treadle pump was 25% and 37% higher than that by the rower and No. 6 hand pump respectively at a head of 2.24-2.32m. The volume of water lifted by the rower pump was 16% higher than that of the No. 6 hand pump.

Cost of Lifting Water and BCR

Benefit-cost ratio and cost of lifting water by the three pumps are given in Table 1. The treadle pump showed the highest BCR and the least cost of lifting water among the three pumps.

CONCLUSION AND SUGGESTION

Twin treadle pump was the best considering the performances regarding discharge, head, power and efficiency for lifting ground water. The farmers of the study area also ranked the treadle pump as the first and then the rower pump for small scale irrigation.

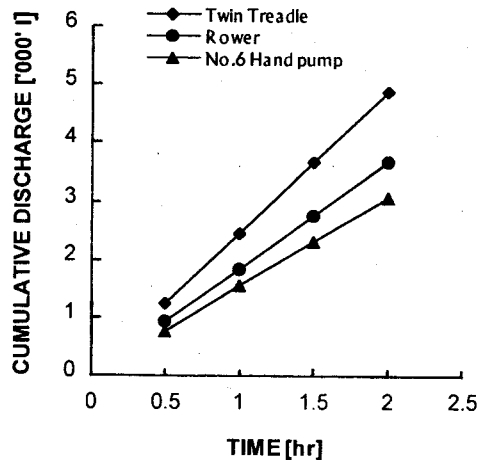

Fig. 7 Cumulative discharge-time relationship of treadle, rower and hand pump

The operation of manually operated pumps are tedious and their discharge is low. Effort should be made to increase the capacity of these pumps. Detail ergonomic study should be conducted for their modifications so as to improve their performances.

REFERENCES

Abdullah, M. (1986). Performance evaluation of manually operated pumps for small scale irrigation in Bangladesh. M. Sc. Thesis. Cranfield Institute of Technology, Silsoe College, Bedford, England. pp. 64.
 Haque, M.A. (1995). On farm performance of manually operated water lifting devices used in Bangladesh.

- M.Sc. Thesis, Department of Farm Power and Machinery, BAU, Mymensingh, Bangladesh. pp. 92.
- Islam, M.S.; M.A.R. Akanda; M.H. Rashid and M.I. Hossain, (1992). Potentiality of manual pump irrigation in Jessore region. Ann. Bangladesh Agric. 2(2): 105-112.
- Islam, M.S.; M.A. Mazed and K.C. Roy (1981). Comparative performance of different types of manual pumps. AMA, Summer. pp. 65-68.
- Islam, M.S.; M.M. Haq; M.A. Baqui; M.T. Islam; M.H.U. Sarkar and K.A. Haq (1992). Operation of manual pumps in the farmers field of Bangladesh. Field evaluation and extension. Bangladesh Rice Journal 3(1&2): 139-143.
- Molenaar, A. (1956). Water lifting devices for irrigation. FAO Agricultural Development Paper No. 60. FAO, Rome. pp. 73.
- Orr, A.; A.S.M.N. Islam and G. Barnes (1991). The treadle pump: manual irrigation for small farmers in Bangladesh. RDRS, Dhaka, Bangladesh. pp. 96.
- Planning Commission. (1990). The Fourth Five Year Plan (1990-1995). Planning Commission, Govt. of the People's Republic of Bangladesh, Dhaka.