

DESIGN AND DEVELOPMENT OF A POWER TILLER MOUNTED SUGARCANE HARVESTER

S. M. I. Hossain¹ M. D. Hussain² M. M. Hossain³ M. Ahiduzzaman⁴

[Date Received : 02.12.1996]

Key words : Sugarcane harvester, Power tiller, Cost, Field capacity

ABSTRACT

A low cost power tiller mounted sugarcane harvester was designed and developed in the Department of Farm Power and Machinery, Bangladesh Agricultural University, Mymensingh. The harvester was mounted at the front of the power tiller. This machine was suitable for cutting the sugarcane only. The harvested cane was gathered manually. The field capacity of the machine was 0.5 ha/day. The total fabricating cost of the machine was Tk. 3955. The cost of harvesting sugarcane was Tk. 1450 and Tk. 986 per ha for manual and mechanical harvesting respectively.

INTRODUCTION

Sugarcane cultivation in Bangladesh is still practiced in conventional method. The introduction of improved agricultural implements have been yet ignored and almost all the cultural operations are done manually using human power and/or animal power. At present only land preparation is partially mechanized and about 10 to 12% sugarcane field in the mill zone are prepared mechanically using tractors with disc plow, offset disc harrow, spring tine cultivator and ridger (SRTI, 1987). All other operations from planting to harvesting are done manually using indigenous tools like country plow, hand hoe, spade and curved knife. Due to use of human power and animal power with indigenous tools, the labour requirement is very high and it is around 400 man-days/ha. Consequently the production cost of sugarcane becomes high.

For cutting, cleaning and loading sugarcane manually in truck or trailer, total labour requirement

per ha was 150 man-days in India (Sharma and Singh, 1985). Harvesting is done manually by using spade and curved knife. Manual harvesting of sugarcane using curved knife always leaves 8 to 16.5 cm of cane stalk with stubble which account for cane losses of 4.42 t/ha (Ali and Matin, 1989). This loss may be substantially reduced by using spade but it is laborious and has low field capacity.

Ratoon cultivation of sugarcane reduces the cost of production nearly 30% or more. But this needs basal harvesting of sugarcane. In manual harvesting the ratoon yield are poor because of the fact that the buds of left over stubble above the ground tend to sprout first. Tender shoot roots from the sprouting base do not reach the soil and in most of the cases the sprouts from such buds do not grow into healthy shoots. Therefore, the first essential requirement is that the cutting of the cane during harvesting should be done close to the ground level. This necessitates the need of introduction of mechanized sugarcane harvesting system in Bangladesh.

¹ Assistant Agricultural Engineer, Agricultural Engineering Division, Bangladesh Sugarcane Research Institute, Ishurdi-6620, Pabna, Bangladesh

² Professor ³ Associate Professor ⁴ Graduate student

Department of Farm Power & Machinery, Bangladesh Agricultural University, Mymensingh 2202, Bangladesh

Sugarcane harvesting in Bangladesh starts from the first week of November (with the start of sugar mills) and it continues up to mid of March every year. But this is also the season of harvesting Aman paddy which starts the first week of November and ends by the mid of December. Beside this, transplantation of Boro paddy also starts from the first week of January and continues up to last week of February. For all these reasons there prevails a shortage of labour for harvesting of sugarcane. Moreover, manual harvesting of sugarcane by curved knife or spade is more cumbersome than other jobs and the labourers are sometimes reluctant to do this job if they get any other jobs. Timely harvesting and ratoon keeping therefore, becomes difficult in case of manual harvesting.

To solve the labour shortage problem during pick demand and for timely harvesting at proper time it is necessary to harvest sugarcane mechanically. Due to the fragmented land and draft power shortage the use of power tiller is increasing day by day. If the mechanical harvesting of sugarcane can be performed by power tiller, farmer will be more benefited and simultaneously the utility of power tiller will also be increased. Therefore, this work has been under taken to design and develop a power tiller mounted sugarcane harvester.

MATERIALS AND METHODS

Design and Fabrication

The harvester was fabricated at the workshop of the Department of Farm Power and machinery, Bangladesh Agricultural University, Mymensingh, Bangladesh. The isometric and front view of the harvester is shown in Fig. 1 and Fig. 2. The materials used for the fabrication of the machine are locally available.

Design Consideration

The following points were taken into the consideration during the design of harvester:

1. The harvester will be mounted at the front of the power tiller for easy operation.

2. The machine will cut one row of sugarcane in the field and push cane in one side.
3. The machine will cut the cane at ground level to avoid the loss of cane with stubble.
4. Power transmission system from engine to machine should be easy.
5. The machine should have two supporting wheels for keeping the base cutter above ground.
6. Adequate safety precautions should be present.

Design of the Functional Parts

The main functional parts of the harvester are (1) Base cutter (rotary cutter), (2) Base cutter holding assembly, (3) Power transmission gear box, (4) Belt pulley, (5) Gear box supporting frame, (6) Guide bar and (7) Supporting rubber wheel (shown in Fig. 1).

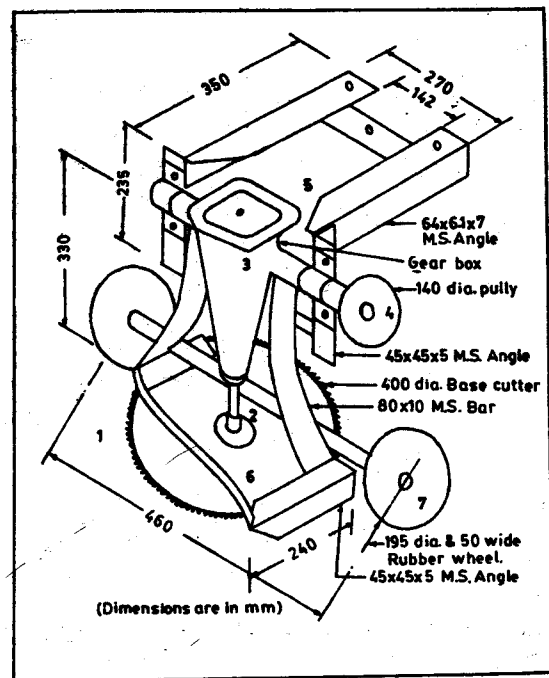

Fig. 1 Isometric view of power tiller mounted sugarcane harvester

Base Cutter

A circular cutter with a serrated cutting edge was used for the sugarcane cutting machine. This type of cutter was considered for the sugarcane harvester as it is cheap and easily available in the market. Detail specification of the cutter is shown below:

Metal	High carbon steel
Diameter	400 mm
Thickness	2 mm
Number of teeth	80
Teeth angle (degree)	28

Base Cutter Holding Assembly

The base cutter holding assembly was made for fixing the base cutter at the end of the vertical shaft of the gear box. The base cutter was bolted between upper guide plate of 85 mm diameter and lower guide plate of 160 mm diameter (Fig. 2) to minimize the vibration of base cutter. The upper guide plate was bolted with the vertical shaft of the gear box.

Power Transmission Gear Box Assembly

Engine power is transmitted to the horizontal shaft of the gear box assembly by a V-belt-pulley drive. From the horizontal shaft, power is transmitted to cutter through bevel gear arrangement (Fig. 3). To get velocity The ratio of engine and cutter rpm was chosen to be 2 : 7 in order to get high cutting speed of the base cutter. A V-belt of B-70 size was selected with the consideration of engine pulley dimension and power to be transmitted (Hossain, 1995).

The gear box was fixed with the vertical bar using nut and bolt providing the facility to lower or raise the box with the range. The whole frame (Fig. 4) could be bolted with the chassis of the power tiller in front by 3 sets of nut and bolts. A compression spring (conical and round wire) as shown in Fig. 5 is attached with the cross flat bar of the vertical member of the frame just behind the gear box to absorb any sudden shock.

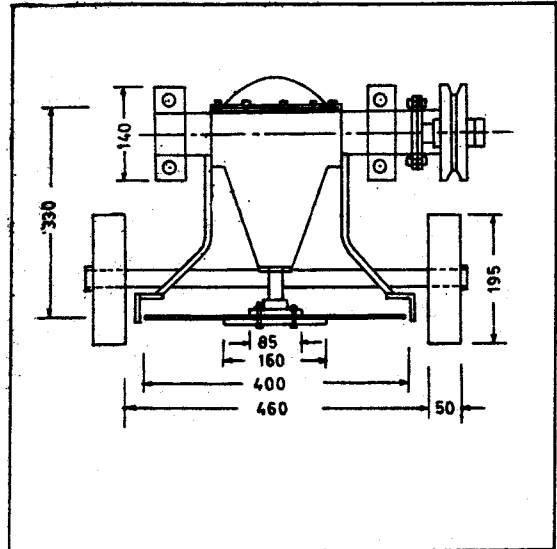

Fig. 2 Front view of the sugarcane harvester

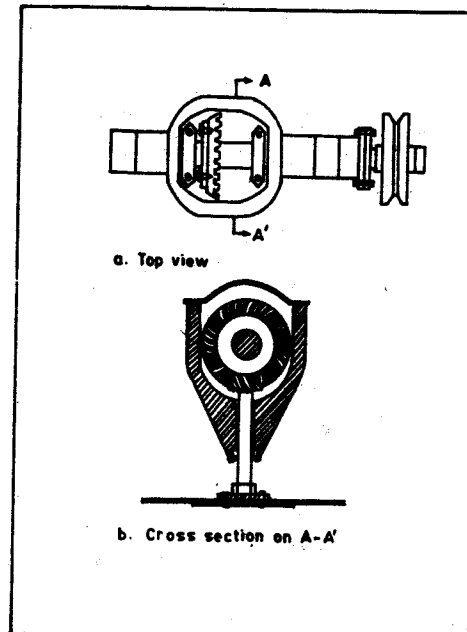

Fig. 3 Power transmission gear box with base cutter assembly

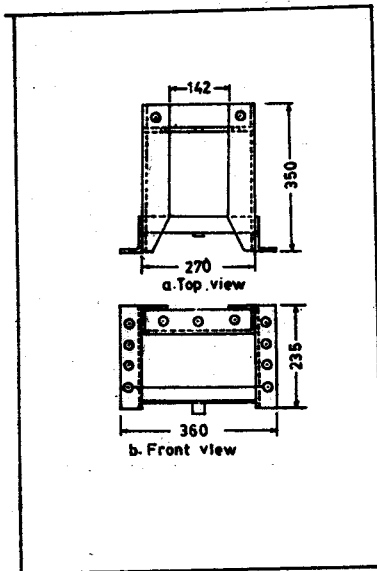

Fig. 4 Gear box supporting frame (dimensions, mm)

Guide Bar

The guide bar (Fig. 6) was designed to guide the cut cane stalks from left to right during operation. The guide bar was made by 38 mm x 3 mm MS flat bar and welded with two 45 mm x 45 mm x 5 mm M. S. angle placed at the two sides of the base cutter and welded with two flat bars which were welded with gear box.

Supporting Rubber Wheels

Two rubber wheels of 195 mm diameter and 50 mm wide was used to support the whole harvesting machine.

Testing of Harvester

The harvesting machine was front mounted on a Dongfeng-12, 8.8 kW, power tiller (Fig. 7). The whole range of the accelerator lever was divided into 5 equal divisions. By changing the accelerator engine was varied. The engine speed, base cutter speed and fuel consumption were measured for each combination of gear 1 and 2 and accelerator position.

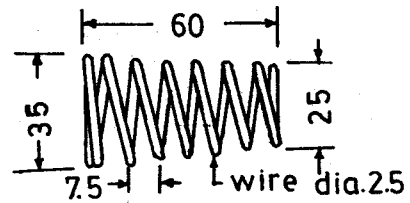

Fig. 5 Compression spring (conical and round wire)

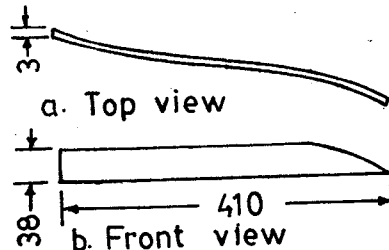

Fig. 6 The guide bar (dimensions, mm)

Field test was carried out in a plot of 50 m x 26 m. Row spacing, plant spacing, cane diameter and height were measured. Number of plant in each bunch was counted. Total time to harvest the plot was recorded. Effective field capacity was determined dividing the plot area by the time required to harvest the cane. Field efficiency, was determined dividing the effective field capacity by theoretical field capacity. Economic analysis was done for comparison of the cost of harvesting by manual and mechanical methods.

RESULTS AND DISCUSSION

For the selected five positions of the accelerator lever, the engine RPM was 750, 1250 and 2000. The corresponding RPMs of the cutting blade were found 2625, 4875, 5250, 6125 and 7000 for both 1 and 2 gear position (Table 1). The forward speeds of the power tiller at five accelerator position for gear 1 were 0.543, 0.865, 0.923, 1.044 and 1.187 km/hr and that for gear 2 were 0.901, 1.423, 1.688, 1.863 and 2.123 km/hr, respectively. The ratio of RPM of the engine to that of the base cutter was 3.5 which is identical with the theoretical ratio.

Table 1 No-load forward speed of power tiller and RPM of the engine at different lever position in gear 1 and 2.

Gear No.	Accelerator lever position	Forward speed of power tiller (km/h)	Engine speed (RPM)	Cutter speed (RPM)	Fuel consumption (ml/h)	Fuel consumption (ml/kWh)
1	1	0.543	750	2625	398	45.2
1	2	0.865	1250	4375	832	94.5
1	3	0.923	1500	5250	914	103.9
1	4	1.044	1750	6125	899	103.2
1	5	1.187	2000	7000	1223	139.0
2	1	0.901	750	2625	181	20.6
2	2	1.423	1250	4375	484	55.0
2	3	1.688	1500	5250	973	110.6
2	4	1.863	1750	6125	1108	125.9
2	5	2.123	2000	7000	1509	171.5

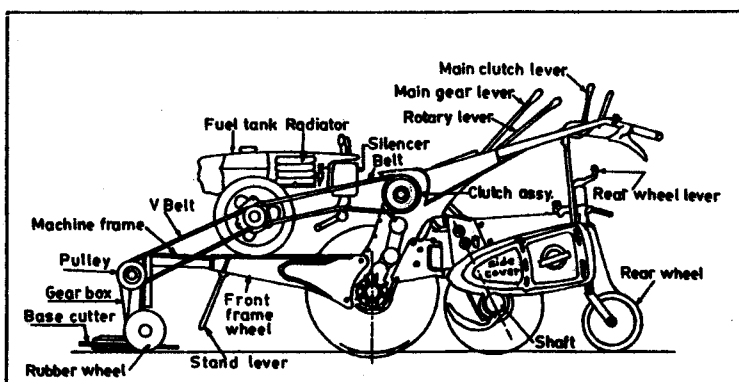

Fig. 7 A complete diagram of the power tiller mounted sugarcane harvester

For no-load condition at about 1500 RPM fuel consumption of the engine was almost the same for both the gear. Therefore, field test was done at this engine speed with gear position 2 to get higher forward speed.

Average cane diameter and height were 18 mm and 2.1 m respectively. Canes per clamp was 3-4 in numbers. Row to row and plant to plant spacing were 0.8 m and 0.3-0.4 m, respectively. Cane production in the field was 40 t/ha. Effective field capacity of the harvester was 0.5 ha/day and field efficiency was 49%.

Total fabricating cost of the harvester was Tk. 3955. Considering the purchase price of the power tiller Tk. 50000 and 90 days/year use of the harvester, total cost of cutting sugarcane including fixed cost of the power tiller and harvester becomes Tk 986. The cost of manual harvesting was Tk. 1450. This indicates that the cost of harvesting sugarcane manually is 50% higher than that by mechanical method.

Canes were on the top of the ridge and some times the base cutter came in contact with hard soil which causing stoppage of the blade rotation and 100% belt slippage.

As there was no provision of adjusting the supporting wheels, the engine was to stop to release the cutting blade from the soil. Hence a provision of raising and lowering of the base cutter should be introduced making the two supporting front wheels adjustable. In addition, the V-belt may be replaced by a chain to reduce belt slippage.

As there was no provision of over-head cane guide bar on the machine, the harvested canes fell scattered on the ground causing the machine to run over the cut canes and creating problems to the laborer for gathering and cleaning them. A over-head cane guide bar should be provided with the machine to solve this problem.

The base cutter was 40 cm in diameter. But the canes were within 15-20 cm in the rows. So there must have base cutter of different diameters with the provision of adjustment on the base cutter assembly.

Estimation of cutting resistance of sugarcane stalks and optimum forward speed of power tiller could not be done due to lack of appropriate instruments and

sufficient information. Further studies on these aspects are suggested. Although the machine was designed for sugarcane harvesting, with simple modification and adjustment it might be used for jute and forest harvesting.

REFERENCES

- Ali, M. and M. A. Matin (1989). Assessment on cane losses due to indiscriminate harvesting. *Bangladesh Journal of Sugarcane* Vol. 1, pp. 114-115.
- Hossain, S. M. I. (1995). Design and development of a power tiller mounted sugarcane harvester. Unpublished M. Sc. Thesis. Dept. of Farm Power and Machinery, B. A. U. Mymensingh.
- Sharma, M. P. and K. Singh (1985). Partial mechanization of sugarcane harvesting. *Agricultural Mechanization in Asia, Africa and Latin America (AMA)* 16(3):47-49.
- SRTI (1987). Annual Report. Sugarcane Research and Training Institute, Pub. No. 47, P. 23.
- Yadav, R. N. S. and N. S. L. Srivastava (1980). Sugarcane harvesting knives used in India. *Indian Society of Agricultural Engineers*. IARI, New Delhi, Paper No. 80-108.