

DEVELOPMENT OF A MANUALLY OPERATED OYSTER SHELL CRUSHER

A. T. M. Ziauddin¹ S. C. Das²

[Date Received : 13.12.1996]

Key words : Crusher, Gear and bearing, Calcium, Poultry feed, Oyster shell

ABSTRACT

A manually operated oyster shell crusher was fabricated and evaluated. The crusher consists of two knurling rollers, two gears, two bush bearings, two adjustment bolts, one handle, one hopper and a tray. When the crushing rollers was powered by hand through a handle, the oyster shell as received through the hopper was crushed by the rotating rollers. The performance tests indicated that the device could crush 17.80, 7.51, 3.76 kg/hr in 1st phase of reduction, 2nd phase of reduction and 3rd phase of reduction, respectively. The average efficiency of the device was found to be 97%. The crusher can be used for crushing of oyster shell, snails etc. with high satisfaction.

INTRODUCTION

Poultry is an important component of agricultural sector in Bangladesh. In rural areas of Bangladesh indigenous breeds of poultry birds are raised mainly by women. Commercial poultry farms are growing day by day. According to Agricultural and Livestock Census (1983-84), there were 9955 small and large poultry farms, 1567 mixed farms and 4041 duck farms, with a total population of 1200 millions. It has been estimated that this population of poultry could produce 20000 millions of eggs per year. The distribution of egg per capita per year is about 18. But egg requirement per capita per year is about 300 to 350. To fulfil this gap, production level of eggs must be increased 18 times from the present production level (Alam, 1994).

Calcium-rich feed is essential to poultry for proper development of egg shell. Literature available reveal that poultry feed with proper calcium source could help increase egg production. Oyster shell, a source of calcium, is abundantly found throughout Bangladesh, especially near the water bodies. During rainy season, the oysters increase their production in large number. In the dry season, when water level of the water bodies falls or dries out, the oyster dies. The shell of the dead oyster could be a very good source of calcium for poultry. But the oyster shell could not be directly consumed by the poultry. Therefore, oyster shell must be crushed into edible sizes. Traditionally, it is performed in a small scale by a piece of stone. This process is very slow and inefficient. It is unsuitable even for small poultry farms because of its low efficiency. A low cost manually operated mechanical device should therefore, be

designed and developed to increase the crushing efficiency. With a view to solve the above problem, an attempt was made to develop an oyster shell crusher. The objectives of the work were (a) to develop an oyster shell crusher for poultry feed and (b) to test and evaluate the performances of the device.

METHODOLOGY

Design considerations

Experiences indicated that five revolutions of the roller in 15 seconds could give better performance of crusher under consideration. The average size of the oyster available is 0.0762 m. The oyster shell need to be reduced from 0.0762 m size to 0.00254 m for easy consumption of the poultry (BAU, 1995).

With appropriate value of the coefficient, C, the Kick's law (Hendersen and Perry, 1980) may be applicable for crushing the shell. The value of C has been assumed to be 10 for oyster shell. Experiment may be necessary to find out the exact value of C.

$$E = C \ln(L_1 / L_2) \quad \dots\dots\dots (1)$$

where,

E = energy

C = constant, 10

L₁ = initial dimension, m

L₂ = reduced dimension, m

On the other hand the energy requirement can also be calculated from the following formula :

¹ Professor ² Post-graduate student

Department of Farm Power and Machinery, Bangladesh Agricultural University, Mymensingh 2202, Bangladesh

$$E = \frac{F \times L \times N \times 3600}{75 \times t} \dots\dots\dots(2)$$

where,

F = force

L = arm length of the crusher's handle

N = no. of revolution

t = time

From equation (1) and (2), the following relationship can be obtained

$$C \ln(L_1/L_2) = \frac{F \times L \times N \times 3600}{75 \times t}$$

$$\text{or, } 10 \ln(0.0762 / 0.00254) = (20 \times L \times 5 \times 3600) / (75 \times 15)$$

Thus, L = 0.1063 m

Therefore, the arm length of the crusher was found to be 0.11 m. The minimum and the maximum spacing between the crusher shafts were maintained 0.76 mm and 3 mm, respectively. The diameter and length of the crusher shaft was 51 mm and 203 mm respectively, so that the sufficient force of crushing could be applied (Fig. 1).

Most of the parts of the crusher were fabricated and tested in the workshop of the Department of Farm Power and Machinery of Bangladesh Agricultural University, Mymensingh. The pictorial view of the oyster shell crusher is shown in Fig. 2. It consists of an oyster hopper, two knurling shafts, gears, bush bearings, supporting plates, a handle, attachment rods, and a tray. Two knurling shafts of the same dimensions were fabricated. They were supported on two vertically placed plates. One shaft was driving and the other was driven. The driven shaft was fixed and driving shaft was adjustable. The clearance between the shafts could be increased or decreased with two adjustable screws. The range of clearance was zero to 3 mm. Both the shafts were connected with two gears of equal size. When the driving gear was rotated with a handle, the power was transmitted to the driven shaft. Both the shafts were rotated in opposite direction and the oyster shells were feed between the shafts. There was a hopper above the shafts and it had a tray to receive the crushed oyster shell.

Laboratory tests were conducted to determine the fineness modulus, capacity of the crusher, power requirement, efficiency of the crusher and the feeding performance of the crusher.

Fineness Modulus

Fineness Modulus of the crushed material was determined by the standard sieve analysis technique and the shaking machine.

Capacity of the Crusher

To test the capacity of the crusher, five samples of oyster shell, each of 25 g were taken. Shafts were rotated by means of a handle and oyster shells were feed between the shafts. The crushed material and time were recorded to determine the capacity of the crusher.

Power Requirement

Arm length of the handle was measured and spring balance was set in the driving shafts. During the rotation of the shafts, revolutions, time in second and force in kg were recorded. Power requirement of the crusher was determined from the following formula.

$$P = \frac{F \times R \times L}{75 \times 60} \dots\dots\dots(3)$$

where, P = power (PS)
 F = force, kg
 R = revolution per minute
 L = arm length of the handle

Efficiency of the Crusher

Five samples each of 25 g were taken and crushed. After crushing, the weight of the samples were taken. The efficiency was determined from the following formula

$$\eta = \frac{W_t - W_c}{W_t} \times 100 \dots\dots\dots(4)$$

where, η = efficiency of the crusher, %
 W_t = weight of the sample before crushing, g
 W_c = weight of crushed sample, g

Feeding Test

Six groups of equal number of ducks and hens from the poultry farm of Bangladesh Agricultural University, Mymensingh were taken for the test. Each group consists of three numbers of poultry. According to the feed rate of poultry farm, 7.5 kg of oyster shell were mixed with 100 kg of feed. The feed mixture were supplied to each group of duck and hen. After 30 minutes, the unconsumed crushed shells were measured and feed intake efficiency was calculated using the following formula :

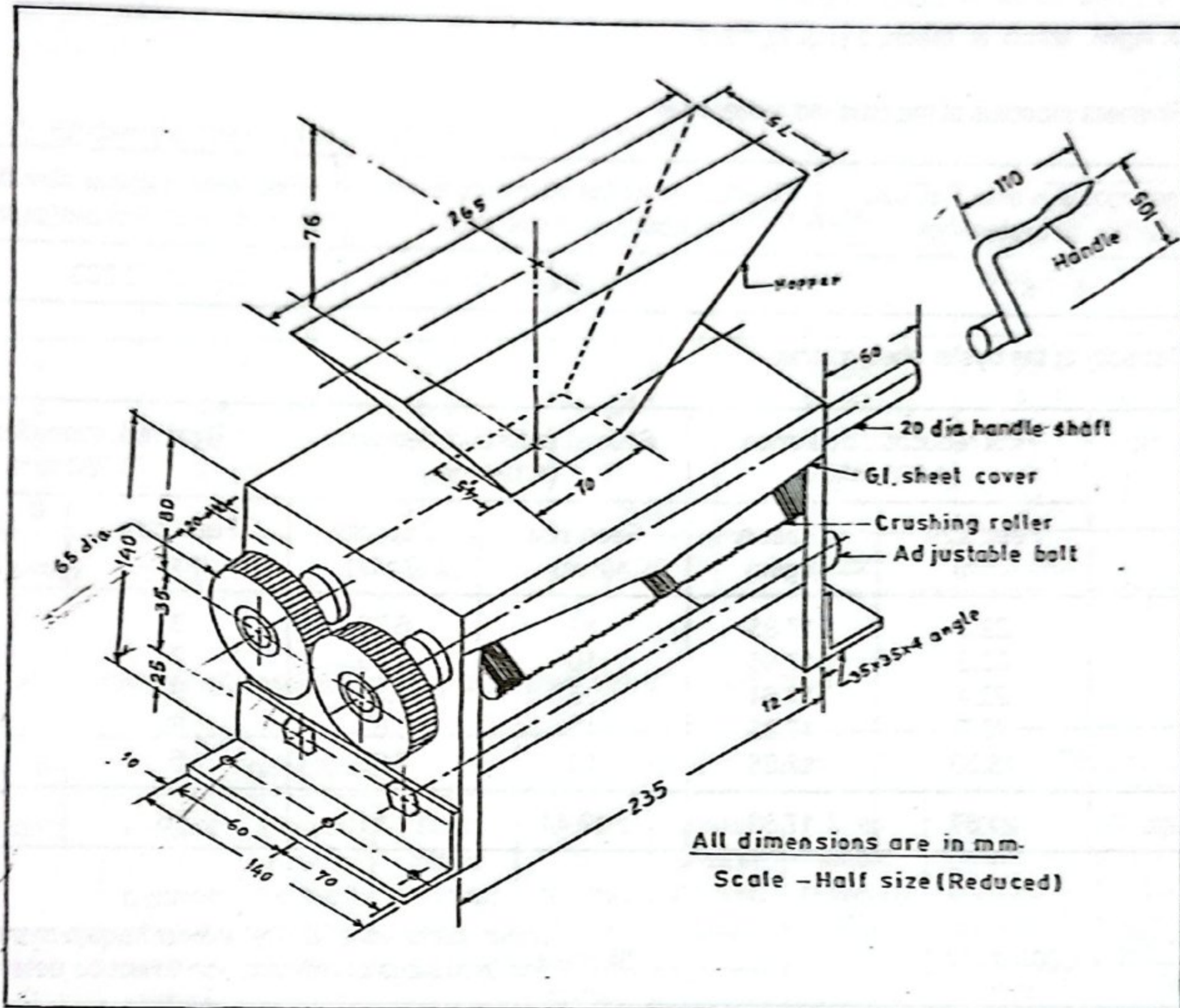

Fig. 1 Isometric view of the oyster shell crusher

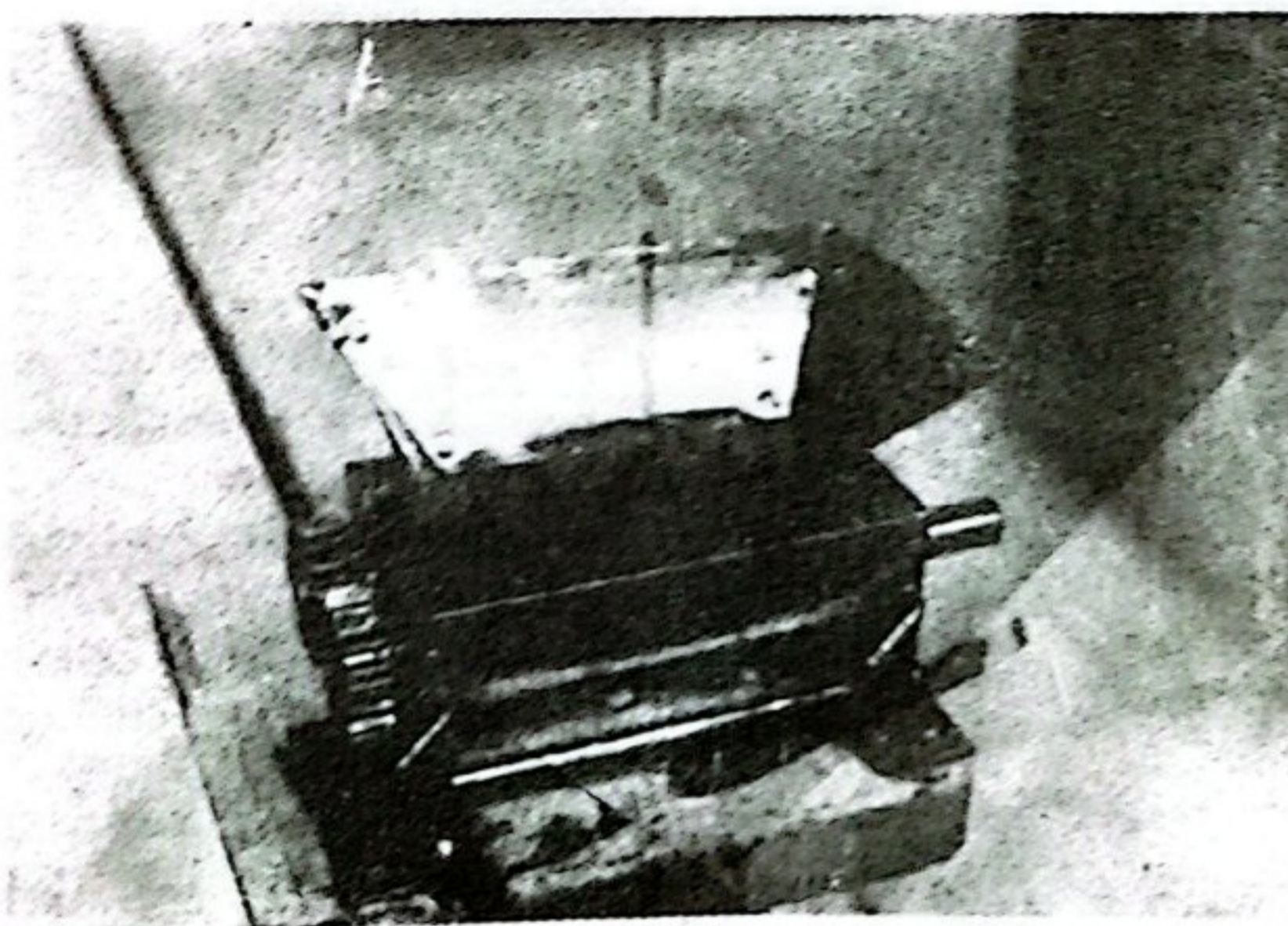

Fig. 2 A pictorial view of the oyster shell crusher

Table 1 Fineness modulus of the crushed oyster shell

Fineness modulus after first size reduction of oyster shell	Fineness modulus after second size reduction of oyster shell	Fineness modulus after third size reduction of oyster shell
4.128	3.124	2.263

Table 2 Capacity of the oyster shell crusher

Sample No.	First reduction clearance (1.905 mm)		Second reduction clearance (1.194 mm)		Third reduction clearance (0.762 mm)	
	Feed size (mm)	Capacity (kg/hr)	Feed size (mm)	Capacity (kg/hr)	Feed size (mm)	Capacity (kg/hr)
1	22.3	17.85	12	6.73	8	4.21
2	22.6	17.86	10	8.93	7	3.85
3	22.4	17.64	15	7.32	9	3.66
4	22.7	17.82	13	6.62	8	3.42
5	18.33	17.85	13	7.95	6	3.68
Average	21.67	17.80	12.4	7.51	7.6	3.76

$$\mu = \frac{W_i - W_u}{W_i} \times 100 \quad \dots\dots\dots(5)$$

where, μ = feed intake efficiency, %
 w_i = initial weight of shell, g
 w_u = unconsumed weight of shell, g

RESULTS AND DISCUSSION

The results indicated that the fineness modulus decreases gradually for first, second and third phases of size reduction. The results of fineness modulus analysis is shown in Table 1.

The results indicated (Table 2) that as the capacity increased the fineness modulus also increased and vice versa. The relationship between capacity and the fineness modulus of the crushed feed could be represented by the following equation

$$Y = - 14.4238 + 7.60 X \quad \dots\dots\dots (6)$$

[R² = 0.953]

where, Y = capacity of the crusher, kg/hr
 X = fineness modulus

The average power requirement for first reduction of size was about 0.075 metric horse power. But due to want of

better instrument facility, power requirement of second and third sizes of reduction could not be determined.

The efficiency of the device for five tested samples is shown in Table 3 and the relationship between the efficiency of the crusher and the fineness modulus of the crushed shell can be represented by the following regression equation.

$$Z = 93.577 + 1.33 X \quad \dots\dots\dots (7)$$

[R² = 0.966]

where,
 Z = efficiency of the crusher, %
 X = fineness modulus

The results of feed intake study is shown in Table 4. It was observed that the intake efficiency was higher for duck than that of hen. Furthermore, the intake efficiency decreased as the feed size increased for both duck and hen.

The Kick's law has been used here for designing the crusher. In case of crushing oyster shell the value of C has been assumed to be 10 because of unavailability of relevant value of C. Additional experiment is needed to determine the exact value of C. Further study with better theory for designing the crusher may be needed.

Table 3 Efficiency of the crusher at various sizes of oyster-shell

Sample No.	After first reduction		After second reduction		After third reduction	
	Weight (g)	Efficiency (%)	Weight (g)	Efficiency (%)	Weight (g)	Efficiency (%)
1	24.8	99.2	24.3	97.98	23.4	95.88
2	24.5	98.0	24.1	98.36	23.5	97.51
3	24.75	99.0	24.4	98.58	23.4	95.90
4	24.90	99.6	24.2	97.18	22.8	94.21
5	24.80	99.0	24.3	97.98	24.0	98.76
Average	24.75	98.96	24.26	98.02	23.42	96.45

Table 4 Feed intake efficiencies of poultry at different size of reduced shell

Number of birds	First reduction			Second reduction			Third reduction		
	Amount of crushed shell in the feed mixture (g)	Unused shell in the feed mixture (g)	Shell intake efficiency (%)	Amount of crushed shell in the feed mixture (g)	Unused shell in the feed mixture (g)	Shell intake efficiency (%)	Amount of crushed shell in the feed mixture (g)	Unused shell in the feed mixture (g)	Shell intake efficiency (%)
1 Duck	7.5	5.1	32.00	7.5	-	100	7.5	-	100
2 Duck	7.5	4.9	34.27	7.5	-	100	7.5	-	100
3 Duck	7.5	4.7	37.33	7.5	-	100	7.5	-	100
Average	7.5	4.9	34.67	7.5	-	100			100
1 Hen	7.5	5.3	29.33	7.5	0.5	93.33	7.5	-	100
2 Hen	7.5	5.4	25.33	7.5	0.6	90.66	7.5	-	100
3 Hen	7.5	5.6	28.00	7.5	0.7	92.00	7.5	-	100
Average	7.5	5.4	27.55	7.5	0.6	91.99			100

CONCLUSION

The oyster shell crusher is suitable for operation by a single person. It is quite capable of crushing the shell to various sizes, and to perform multiple functions such as crushing of oyster shell, crushing of snail and grinding of fertilizer. The costs of the crusher is within the reach of small and medium farmers.

REFERENCES

- Alam, M. K. 1994. Modern Poultry Farming, 1st edition. October 1994, Sufia Alam Publication.
- Hendersen, S. M. and R. L. Perry 1980. Agricultural Process Engineering. 3rd edition. The AVI Publishing Company, Connecticut, p-141.
- BAU Poultry Farm, 1995. Personal communication with Farm Manager, Bangladesh Agricultural University, Mymensingh, Bangladesh.